



MK2200L

Features

- Multifunction numerical relay
- Three-phase, three stages setting for phase overcurrent
- Two stages setting for earth fault
- IDMT and definite time
- Thermal overload protection
- Two groups of protection settings
- Trip circuit supervision
- Circuit breaker failure protection
- RS232 and RS485 MODBUS-RTU communication
- Fault, alarm and tripping records with timestamp
- Multifunction programmable outputs
- Multifunction digital inputs
- Complies with IEC 60255 standard
- ANSI code : 49RMS, 50P, 50G, 50N, 51P, 51G, 51N, CLP, 50BF, 74TC

Combined Overcurrent & Earth Fault Relay

Technical Data

AUXILIARY SUPPLY

Model MK2200L-150D

Rated voltage : 30 ~ 120 V DC
Operating voltage : 24 ~ 150 V DC

Model MK2200L-240AD

Rated voltage : 100 ~ 240 V AC or
140 ~ 340 V DC
Operating voltage : 85 ~ 265 V AC or
110 ~ 370 V DC
Rated frequency : 50 or 60 Hz
Operating frequency : 45 ~ 65 Hz
Power consumption : 8 VA max

CURRENT INPUTS

Rated current, I_n , I_{on} : 1 or 5 A by connection
Frequency : 50 or 60 Hz nominal
Burden : < 0.025 VA (1 A)
< 0.3 VA (5 A)
Thermal withstand : 4 x I_n continuous
40 x I_n for 2s
100 x I_n for 1s

DIGITAL INPUTS

Input type : Optically isolated
Rated voltage : 20 ~ 380 V DC
50 ~ 270 V AC

OUTPUT CONTACTS

Trip Contact Relay R1, R2, R3, R4, IRF Relay

Rated voltage : 250 V AC / DC
Continuous carry : 5 A
Expected electrical life : 100,000 operations at rated load
Expected mechanical life : 5 x 10⁶ operations

RECORDS

Fault Record : Up to 50 records
Event Record : Up to 250 records
Alarm Record : Up to 30 records

SETTING RANGES

GENERAL

Line CT primary : 1 to 10,000 A
Earth CT primary : 1 to 10,000 A
Frequency : 50 or 60 Hz

PHASE OVERCURRENT

$I >$: 0.1 to 25 x I_n (Recommended up to 2 x I_n for IDMT delay)
*(Variable Steps)
 $I >$ Delay type : IDMT or definite time
 $tI >$: 0 to 100 s *(Variable Steps)
 $I >$ IDMT curve: NI, VI, EI, LTI, NI 1.3/10
 ktI : 0.01 to 1.00 (Step 0.01)
 $I >>$: 0.5 to 40 x I_n *(Variable Steps)
 $tI >>$: 0 to 100 s *(Variable Steps)
 $I >>>$: 0.5 to 40 x I_n *(Variable Steps)
 $I >>>$ Sample : Yes or No
 $tI >>>$: 0 to 100 s *(Variable Steps)

EARTH FAULT

$I_o >$: 0.02 to 2 x I_{on} (Recommended up to 0.5 x I_{on} for IDMT delay)
 $I_o >$ Delay type : IDMT or definite time
 $tI_o >$: 0 to 100 s *(Variable Steps)
 $I_o >$ IDMT curve: NI, VI, EI, LTI, NI 1.3/10
 ktI_o : 0.01 to 1.00 (Step 0.01)
 $I_o >>$: 0.1 to 10 x I_{on} *(Variable Steps)
 $tI_o >>$: 0 to 100 s *(Variable Steps)

THERMAL OVERLOAD

$I\theta >$: 0.1 to 3 x I_n *(Variable Steps)
 $T\theta$: 1 to 200 minutes (Step 1)
 k : 1 to 1.5 (Step 0.01)
 θ Trip : 50 to 200% (Step 1%)
 θ Alarm : 50 to 200% (Step 1%)

* Variable Steps: 0.1-1.00: Step 0.01;
1.00-20: Step 0.1; >20: Step 1

MEASUREMENT RANGES

Phase Current Secondary:
5 A input : 0 to 200 A
1 A input : 0 to 40 A

Earth Current Secondary:
5 A input : 0 to 50 A
1 A input : 0 to 10 A

ENVIRONMENTAL CONDITIONS

Temperature : -10°C to 55°C
Humidity : 5% to 95%, non-condensing

MECHANICAL

Mounting : Panel mounting
Dimension (mm) : 142(w) x 165(h) x 198(d)
Enclosure protection: IP54 at the panel
Approximate weight: 2.2 kg

ACCURACY

Current accuracy : ± 3% of the set value or 20mA secondary
Timing accuracy : ± 5% or ± 30ms

COMMUNICATION

RS232 (front) : MODBUS-RTU
RS485 (back) : MODBUS-RTU

MK 2200L

Normal Inverse

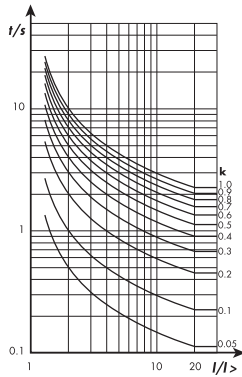

Very Inverse

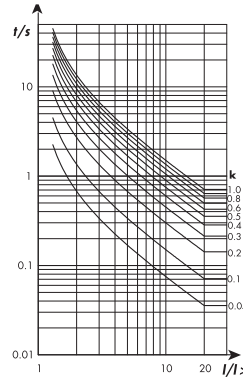

Long Time Inverse

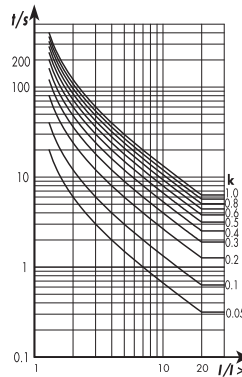

Extremely Inverse

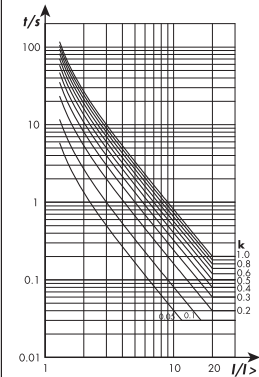

Typical Application Diagram 1

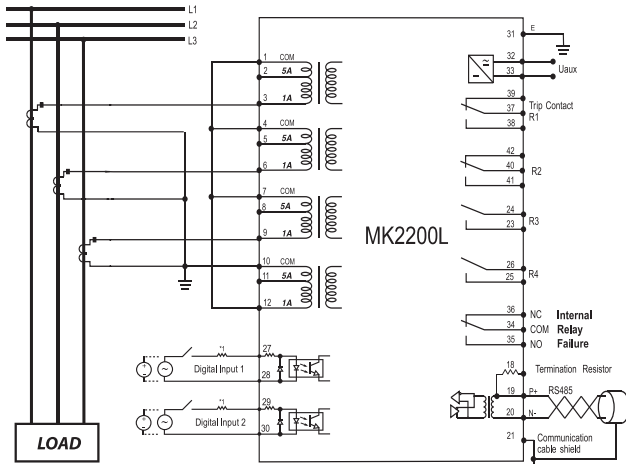

*1 Series resistor 18k Ohm, 2W required for >170 Vac / 240 Vdc to 270Vac / 380Vdc

Case Dimensions

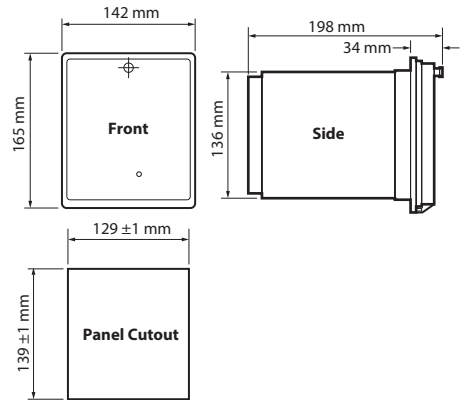

Typical Application Diagram 2

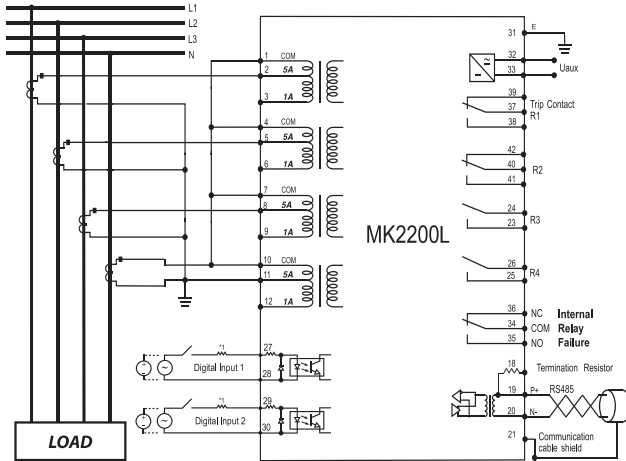

*1 Series resistor 18k Ohm, 2W required for >170 Vac / 240 Vdc to 270Vac / 380Vdc

Ordering Information

MODEL	DESCRIPTION
MK2200L - 150D	For 50/60 Hz, auxiliary voltage 24 ~ 150 V DC
MK2200L - 240AD	For 50/60 Hz, auxiliary voltage 85 ~ 265 V A or 110 ~ 370 V DC